

1. 一般注意事項	1
1-1 交貨檢查	1
1-2 運輸時注意事項	1
1-3 放置地注意事項	1
1-4 安裝檢查	2
1-5 維修時注意事項	2
1-6 添加液注意事項	2
2. 單螢幕控制面板說明	3
2-1 控制面板外觀圖樣	3
單螢幕配電線路圖	4
2-2 按鍵操作說明	4
3. 單螢幕 一般溫控模式操作說明	4
3-1 啟動關閉冷卻機	4
3-2 設定控制溫度	4
3-3 觀看室溫	4
4. 單螢幕功能設定模式操作說明	5
4-1 進入功能設定模式	5
4-2 修改設定值	5
4-3 結束設定	5
故障信息代號及排除方法	5
5. 雙螢幕控制機板說明	6
5-1 控制面板外觀圖樣	6
5-2 按鍵操作說明	6
6. 雙螢幕一般控溫模式操作說明	6
6-1 啟動關閉冷卻機	6
6-2 設定控制溫度	6
6-3 觀看室溫	7
雙螢幕機板警報信號說明	7
7. 雙螢幕控制機板配線圖	8
7-1 配線注意事項	8
7-2 控制機板電氣配線圖	8
8. 各零件復歸說明	9
9. 保養與維護	10
售後服務保證書	11
English Operation Manual	12~23

1.一般注意事項

親愛的客戶：

感謝您使用本公司的產品，為確保使用上正確性及安全性，請先詳閱本操作說明。本公司產品機型及應用規格多樣，大致分為水用冷卻機及油用冷卻機，有(油／水箱)，無(油／水箱)、或有(泵浦)、無(泵浦)，使用時請特別注意規格。

1-1 交貨檢查：

機器運輸下貨後檢查外觀是否有碰撞損傷，與報價洽商時的規格與需求是否符合。

1-2 運輸時注意事項：

- 搬運時請使用適當的堆高機或天車。
- 吊運時注意機器重量使用符合承載的繩索及工具(重量標示於機器名牌上)。
- 運送時請勿傾斜或橫躺。
- 運送時請使用繩索或其他方式將機器固定，避免運送時移動碰撞損傷。

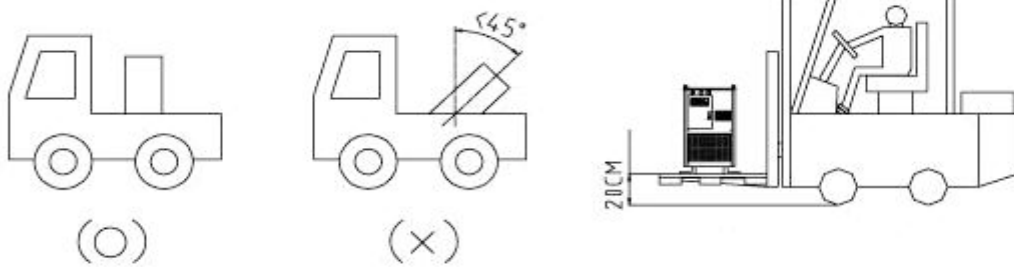

1-3 放置地注意事項：

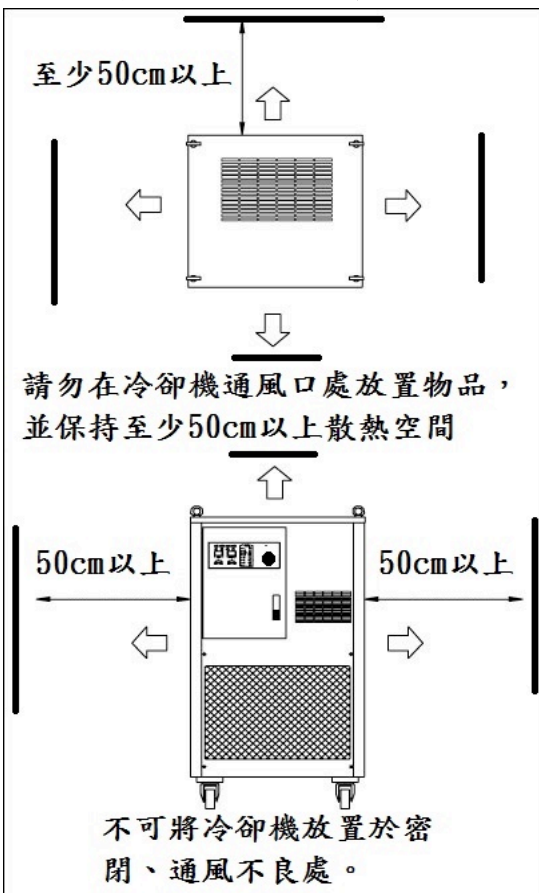

- 請將機器放置於水平位置，避免壓縮機或馬達等零件偏心運轉導致故障。
- 放置機器之位置，機器四周須留散熱空間至少50cm以上，放置處不可為密閉空間。
- 避免放置於不通風場所，適用環境溫度為5~40℃。
- 避免放置於有油氣、揮發性液體氣體、遠離火源之危險性場所。
- 避免放置於有陽光直接照射、或潮濕、雨淋、雷擊之場所，防止電器零件短路損壞。
- 冷卻機移動後請停置30分鐘再行開機，以免壓縮機潤滑油停置在冷凍迴路。

1-4 安裝檢查：

- 各進出口接頭管路是否安裝完成，並注意接頭管路是否漏水。
- 液位是否加到確實位置(液位計之HIGH的標示)。
- 啟動前各管路球閥是否開啟。
- 確認外人電源與機器電源規格，相位、電壓、頻率是否符合，請參照冷卻機銘牌上標示的總耗用電流，來配置正確的電源線線徑及保護開關。

電源端子台及故障點接線

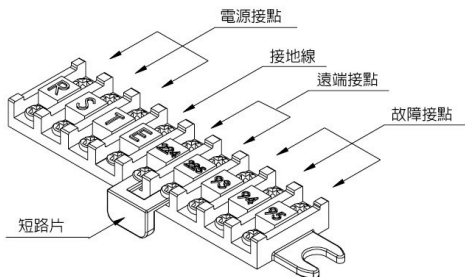

線 號	正常運轉時		出現故障時	
	93 . 95			
93 . 94				

1-5 維修時注意事項：

- 維修時務必確認電源已關閉。
- 非專業維修人員請勿拆卸板金，以免發生(觸電、散熱葉片打傷、燙傷)之危險。
- 進行維修時請將冷卻機總電源關閉，確認冷卻機入電端子台無電源後方可維修。
- 進行冷凍系統維修需由專業冷凍技師進行維修。

1-6 添加液體注意事項

液體限制：

油冷卻機適用礦物系之油壓油和潤滑油，嚴禁使用其他冷卻液，(建議使用油品番號 2~68 號油)。
 水冷卻機適用水、乙二醇、DI 水...等(不可使用揮發性高或易燃液體及具腐蝕性危險液體)。
 使用的油料黏度過高或過低時，泵浦將可能產生不正常的聲響或影響降溫效果，此時請更換適當黏度的油料。

油黏度參考表：

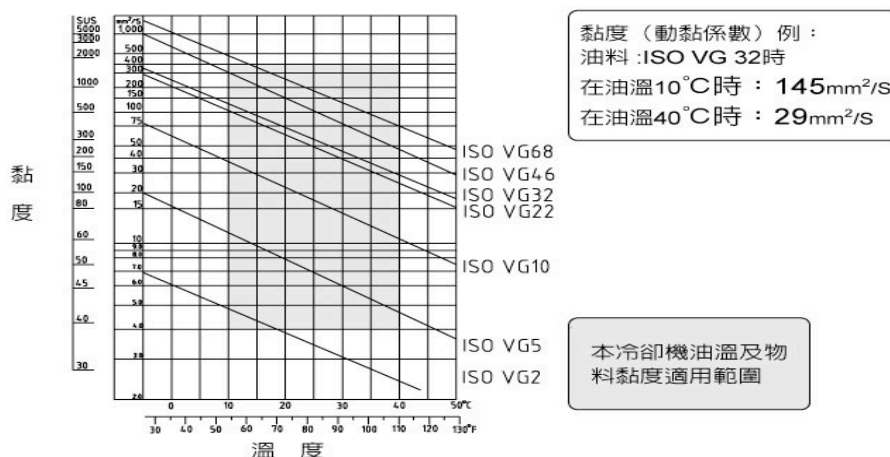

2.單螢幕控制面板說明

2-1 控制面板外觀圖樣

示燈號說明

POWER: 電源指示燈，送電後亮起

PUMP : 幫浦指示燈，亮起幫浦啟動

COOL : 壓縮機指示燈，當燈號閃爍時
表示壓縮機啟動保護中。

ALALM: 警報指示燈

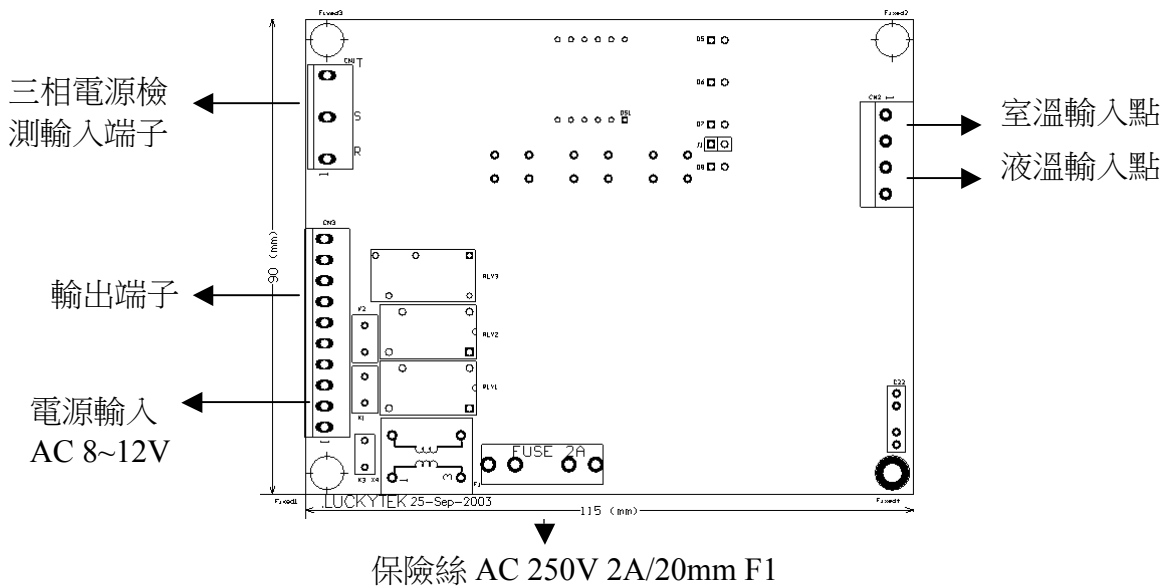
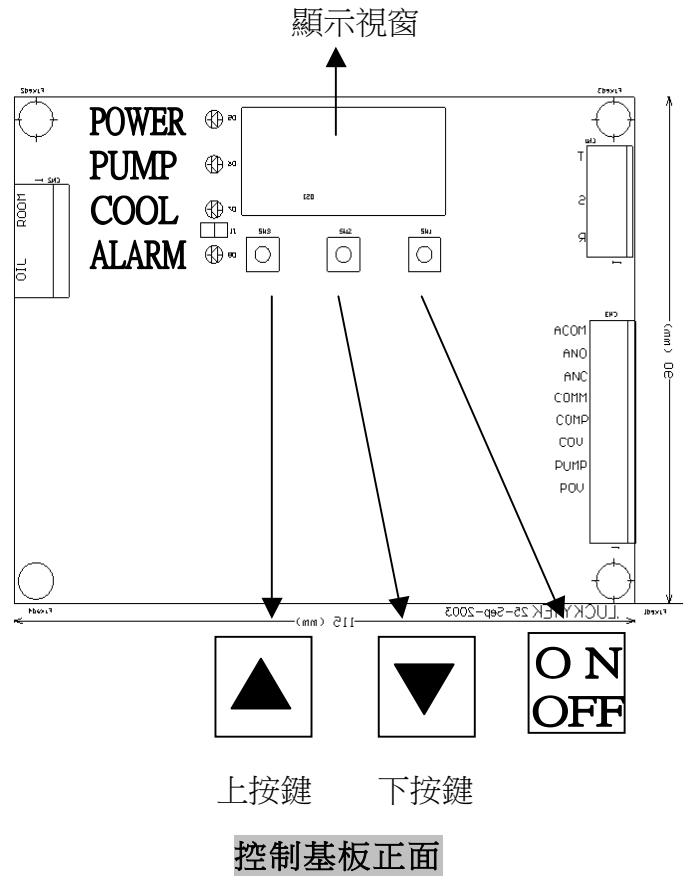

單螢幕基板線路圖

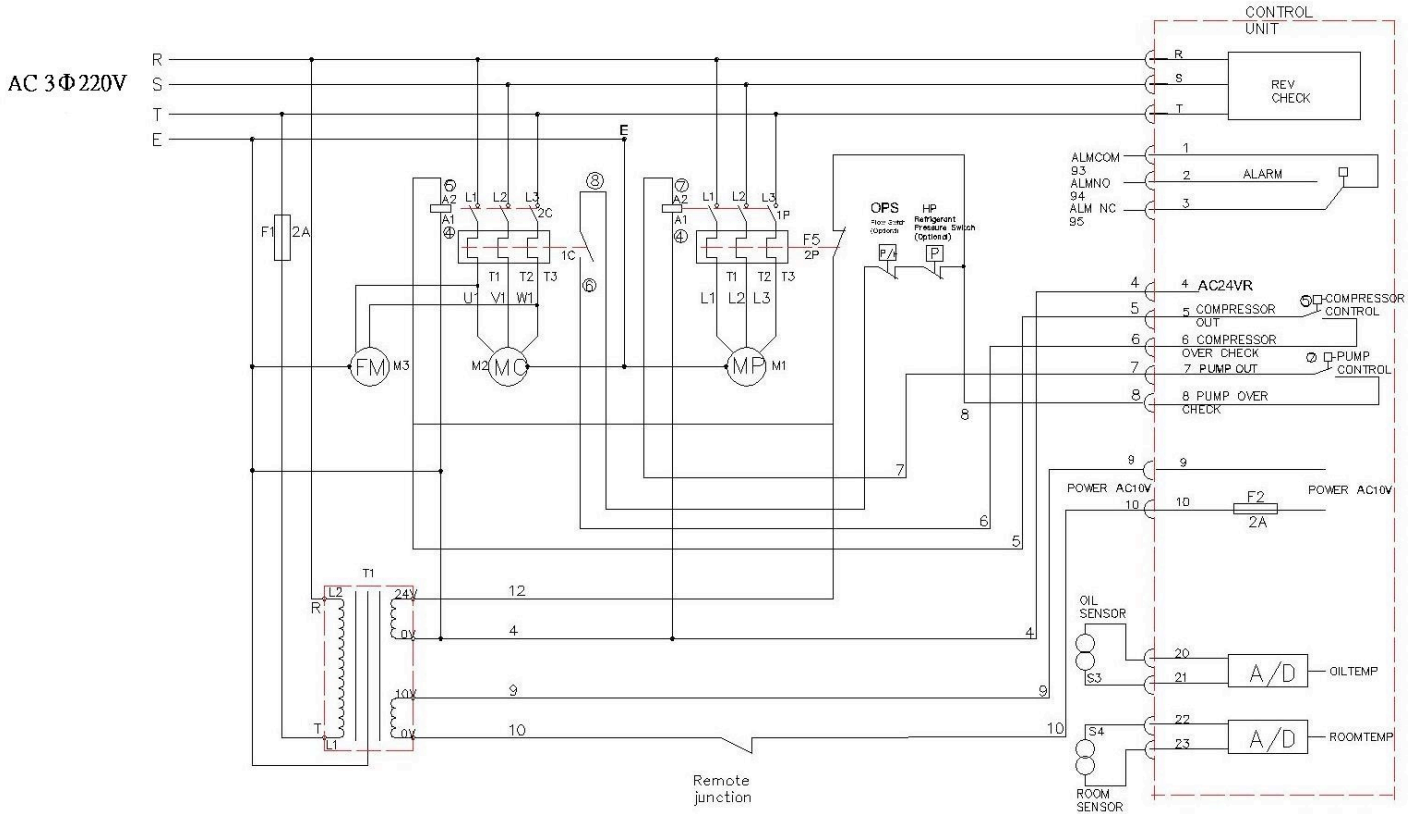

2-2 按鍵操作說明：

按鍵一般模式

ON/OFF：關閉 / 啟動控制器。

設定模式：選擇功能選項/按住2秒跳離設定模式

▲：增加設定值/開啟設定

▼：減少設定值/顯示室溫

3單螢幕一般控溫模式操作說明

3-1 啟動關閉冷卻機

按 **ON/OFF** 一下啟動，再按一下關閉。若功能[F09] 設定為ON，啟動關閉要從電源控制

3-2 設定控制溫度

先按 **▲** 一下進入溫度設定模式(7段顯示器閃爍)。

按 **▲** 可增加設定值，若一直按住 大約 1 秒後會快速累加，直到最大設定值
 按 **▼** 可減少設定值，若一直按住 大約 1 秒後會快速減少，直到最小設定值。

修改完成後不再按按鍵，大約3秒後會自動存入記憶體中。

3-3 觀看室溫

按住 **▼** 不放，溫度視窗會顯示室溫(最後一個小數點會閃爍)，直到放開按鍵。



4.單螢幕功能設定模式操作說明

4-1 進入功能設定模式

在一般狀態下(不論是開機或關機)，同時按住   兩鍵大約3秒後會進入功能設定模式，[F01]顯示0.8秒後與設定交互閃爍。若有設定[F10]則會進入功能設定[F99] 要求輸入密碼，顯示0.8秒後與設定交互閃爍，輸入正確數字進入[F01]。

密碼確認過一次後到下次重送電前都不需再次確認。

4-2 修改設定值

- 按  可增加設定值，若一直按住 大約 1 秒後會快速累加，直到最大設定值
- 按  可減少設定值，若一直按住 大約 1 秒後會快速減少，直到最小設定值。
- 按  可確認輸入 並儲存設定值到記憶體中，並切換設定選項至下一項目。

若沒有更動設定值會直接切換設定選項至下一項目。

修改完成後不再按按鍵，大約3秒後會自動存入記憶體中，功能選項與設定交互閃爍。

4-3 結束設定

 一直按住大約 2 秒後退回到退回一般狀態顯示模式。

單螢幕基板故障信號代號

顯示代號	警報原因	控制器動作	檢查及排除方法
[AL1]	電源逆相或缺相 (REV)	馬達輸出: OFF 壓縮機輸出: OFF 警報燈: ON	1. 使用三用電錶檢查外入電源是否正常，3相需平衡± 10%內。 2.若為單相機型，請將功能設定中F18項設為OFF。
[AL2]	馬達過載異常 (PUMP) 51P	馬達輸出: OFF 壓縮機輸出: OFF 警報燈: ON	1. 檢查所有進出口管路是否異物阻塞 2.檢查電源是否正常。 3.泵浦過載保護器設定值是否正確。 4.馬達過載保護器按下復歸。
[AL3]	COMP壓縮機過載異常51C OPS液位不足， 流量壓力開關跳脫 HP冷媒壓力開關跳脫	馬達輸出: OFF 壓縮機輸出: OFF 警報燈: ON	1.檢查散熱是否正常，散熱風扇是否運轉。 2.電源是否正常。 3.壓縮機過載保護器設定值是否正確。 4.檢查水箱水位是否不足，水位須加至8分滿以上。 5.泵浦是否正常運轉或反轉。 6.泵浦吸入口處是否異物阻塞。 7.過濾網或散熱器太髒，散熱不良。
[AL4]	室溫感溫器故障 (RA)	馬達輸出: OFF 壓縮機輸出: OFF 警報燈: ON	更換室溫感溫器
[AL5]	液溫感溫器故障 (RO)	馬達輸出: OFF 壓縮機輸出: OFF 警報燈 : ON	更換液溫感溫器
[AL6]	超溫保護警告 (OT)	馬達輸出 : ON 壓縮機輸出: ON 警報燈 : ON	1. 確認超溫保護設定參數值。 檢查無法降溫原因。 (壓縮機是否運轉)。

5. 雙螢幕控制面板說明

5-1 控制面板外觀圖樣

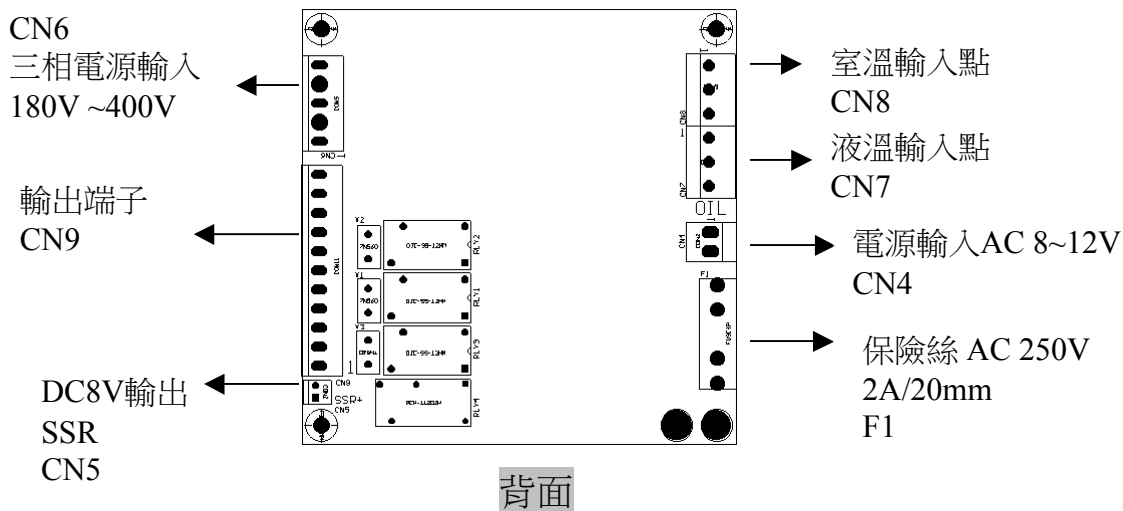
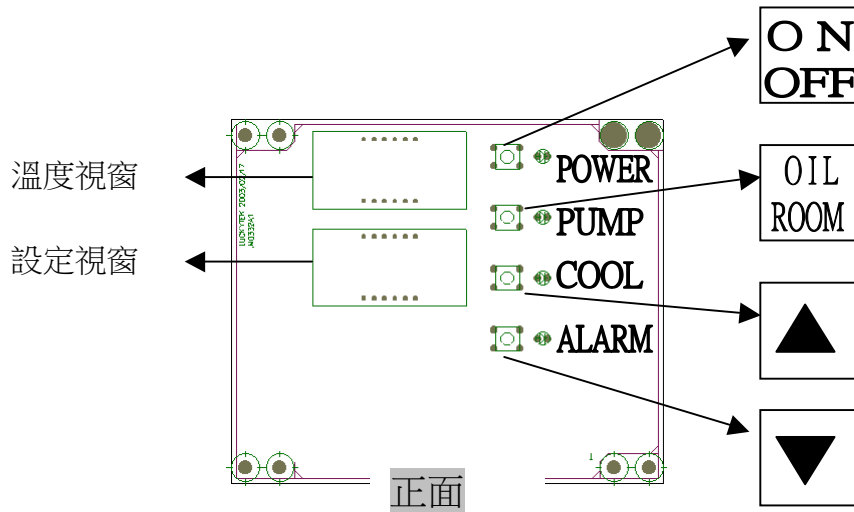

5-2 按鍵操作說明：

按鍵



：一般模式:關閉 / 啟動控制器。

功能設定模式:跳離功能設定模式



：一般模式:顯示室溫5秒後切回顯示液溫。

功能設定模式:選擇設定項目。



：增加設定值。



：減少設定值。

6. 雙螢幕一般控溫模式操作說明

6-1 啟動關閉冷卻機

按 一下啟動，再按一下關閉。

6-2 設定控制溫度

按 可增加設定值，若一直按住 大約 1 秒後會快速累加，直到最大設定值

按 可減少設定值，若一直按住 大約 1 秒後會快速減少，直到最小設定值。

修改完成後不再按按鍵，大約2秒後會自動存入記憶體中。

6-3 觀看室溫

按  一下，溫度視窗會顯示室溫，並且閃爍5秒後切回顯示液(水)溫。

雙螢幕機板警報信號說明

面板代號	警報原因	控制器動作		檢查及排除方法
		[F14]		
[AL1]	電源逆相或缺相，(REV)	馬達輸出 : OFF 壓縮機輸出 : OFF 警報燈 : ON	ON OFF ON	1.使用三用電錶檢查外入電源是否正常，3相需平衡±10%內。 2.若為單相機型，請將功能設定中F18項設為OFF。
[AL2]	缺水，(OPS)	馬達輸出 : ON 壓縮機輸出 : OFF 警報燈 : ON	OFF OFF ON	1.檢查水箱水位是否不足，水位須加至8分滿以上。 2.泵浦是否正常運轉或反轉。 3.泵浦吸入口處是否異物阻塞。
[AL3]	馬達過載跳脫，(PUMP) 51P	馬達輸出 : OFF 壓縮機輸出 : OFF 警報燈 : ON	OFF OFF ON	1.檢查所有進出口管路是否異物阻塞 2.檢查電源是否正常。 3.泵浦過載保護器設定值是否正確。
[AL4]	壓縮機過載跳脫，(COMP) 51C	馬達輸出 : ON 壓縮機輸出 : OFF 警報燈 : ON	OFF OFF ON	1.檢查散熱是否正常，散熱風扇是否運轉。2.電源是否正常。3.壓縮機過載保護器設定值是否正確。4.過濾網或散熱器太髒，散熱不良。
[AL5]	冷煤壓力異常，(HP)	馬達輸出 : ON 壓縮機輸出 : OFF 警報燈 : ON	OFF OFF ON	1.檢查散熱是否正常，過濾網或散熱器太髒，散熱不良。排除散熱方面問題，或散熱風扇故障。2.冷媒洩漏。
[AL6]	室溫感溫器故障，(RA)	馬達輸出 : ON 壓縮機輸出 : OFF 警報燈 : ON	OFF OFF ON	更換室溫感溫器
[AL7]	液溫感溫器故障，(RO)	馬達輸出 : ON 壓縮機輸出 : OFF 警報燈 : ON	OFF OFF ON	更換液溫感溫器
[AL8]	超溫保護警告，(OT)	馬達輸出 : ON 壓縮機輸出 : ON 警報燈 : ON		1.確認超溫保護設定參數值。 2.檢查無法降溫原因。(壓縮機是否運轉)。
[AL9]	低溫保護警告，(LT)	馬達輸出 : ON 壓縮機輸出 : OFF 警報燈 : ON		1.檢查低溫保護設定值。 2.校正感溫器。
Power燈亮，但螢幕無顯示	送電後未開機	馬達輸出 : OFF 壓縮機輸出 : OFF 警報燈 : ON		按一下面板上on/off鍵

7控制機板配線圖

7-1 配線注意事項

1. 在安裝機板或其他所連接之週邊設備時，必須將所有電源關閉，否則會有觸電或損壞設備之可能。
2. 在完成所有安裝線配作業後，請檢查電源及各接線是否有短路現象，確認後才可通電測試。
3. 提供機板之主要電源線要對絞以降低干擾信號。
4. 感溫線不可與動力線接近避免干擾信號造成顯示溫度跳動。
5. 對於使用環境具有油煙、導電性灰塵、高溫、高溼、腐蝕性氣體、可燃性瓦斯、有風雨、結露及高震動衝擊等環境場所請勿使用，若欲使用請做好保護措施。

7-2 雙螢幕控制機板電氣配線圖

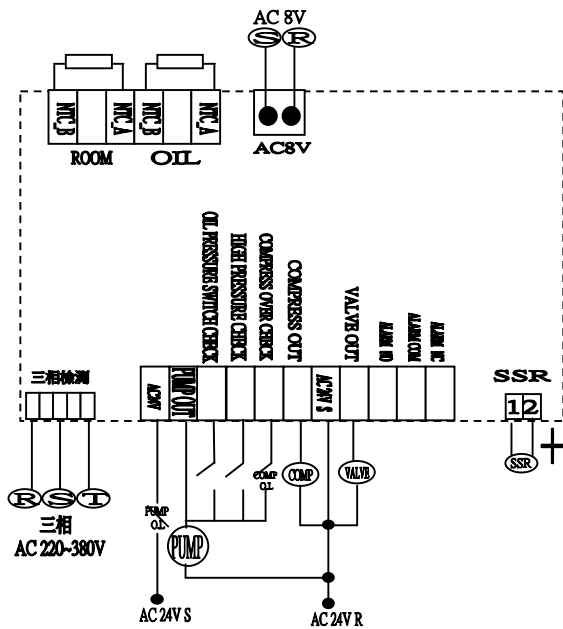

MC 壓縮機馬達	MP 泵浦馬達	PE 接地線
51C 壓縮機馬達 電磁開關	51P 泵浦馬達 電磁開關	ST-RY 啟動電譯
HP 高壓開關	OPS 油壓開關	RA 室溫感測線
51C O.L 壓縮機過載器	51P O.L 泵浦 馬達過載器	RO 液溫感測線
CS 啟動電容	RL 繼電器	TF 變壓器
49C 壓縮機內置 過載器	FS 保險絲	

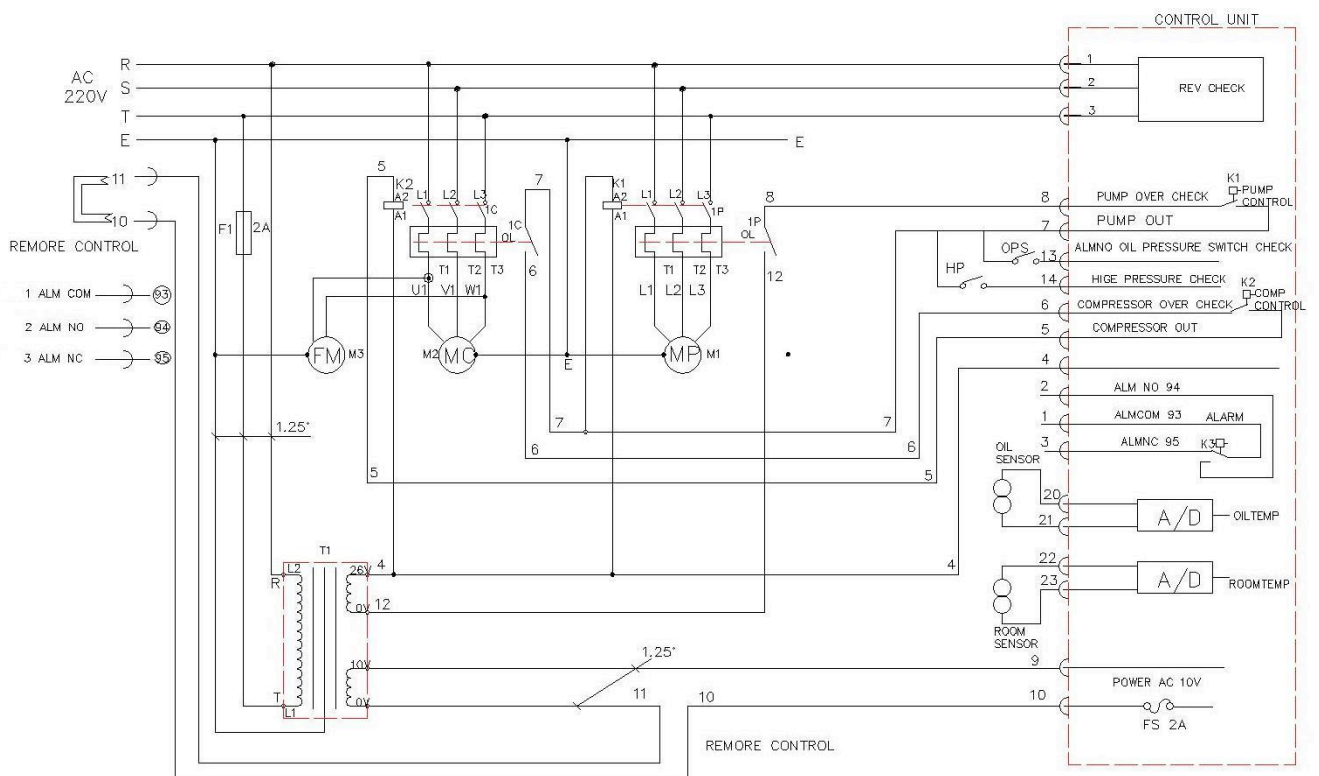

8.各零件復位說明

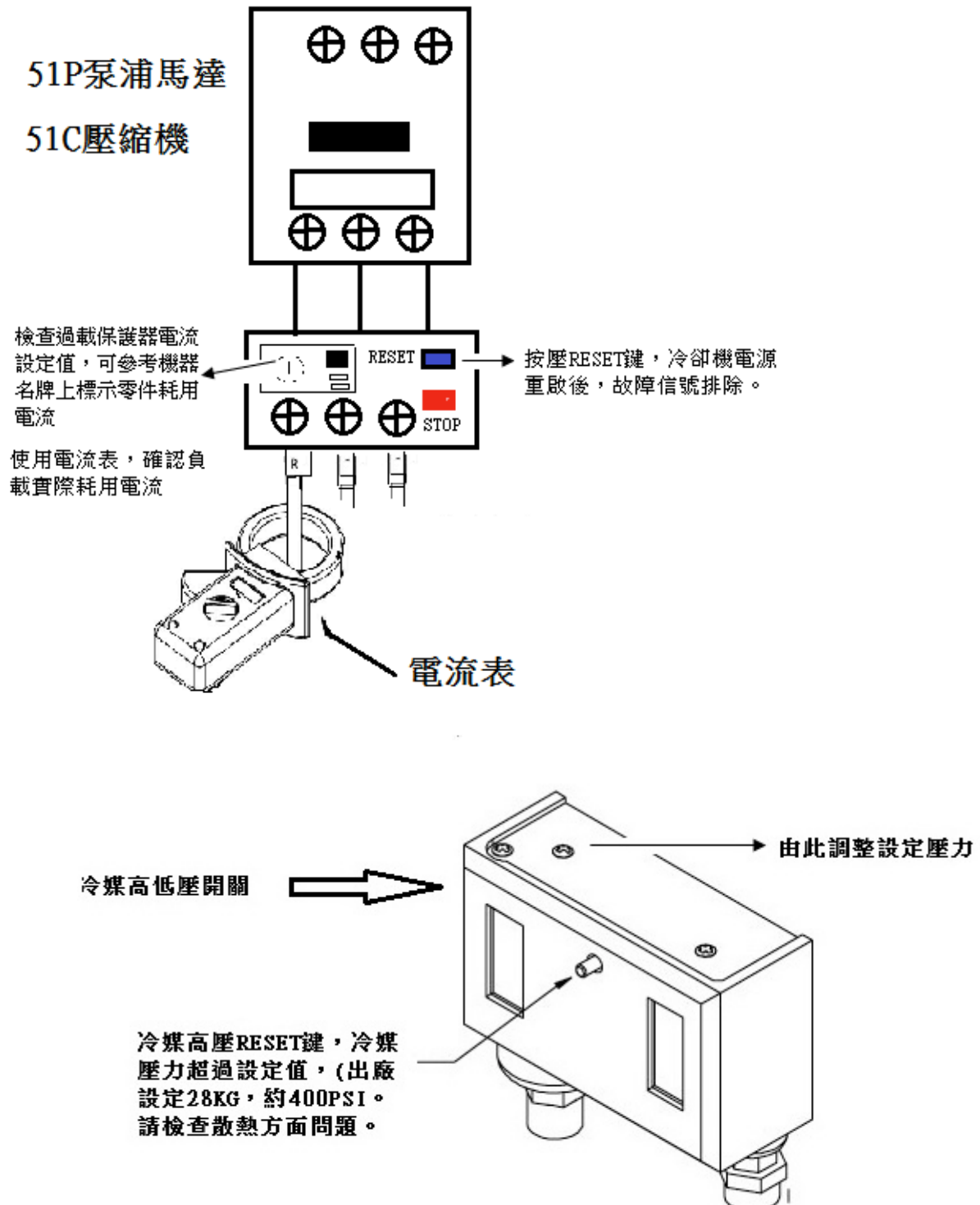

9.保養與維護

- 進行保養時，請務必將冷卻機電源關閉，以免碰觸到熱源或者是碰觸到風扇，造成傷害。
- 機體外型保養，請使用中性清洗劑或肥皂清洗表面污垢，切勿使用酸性溶劑以免腐蝕表面烤漆。
- 清洗時嚴禁將水噴掃到電控部份，以免造成電器受損。
- 定期作過濾網清潔保養，每週定期使用噴槍清潔塵埃，或清洗劑與水沖洗。
- 定期使用壓縮空氣清除冷凝器的灰塵，空氣噴槍須與散熱鰭片成垂直方向上下噴吹。
- 若冷卻機進口或出口位置有裝過濾器時，請定期更換或清洗濾心

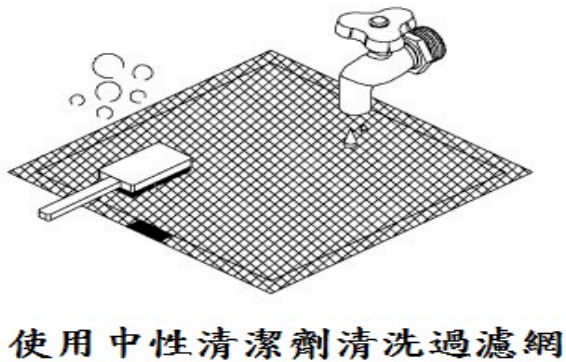
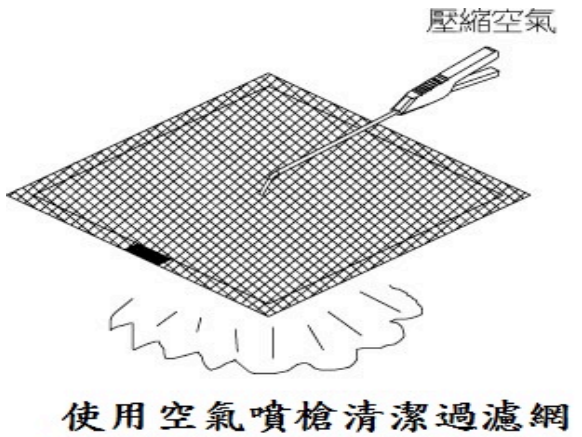

1. General Precautions	13
1-1 Delivery check	13
1-2 Precautions when transporting	13
1-3 Precautions placed in	13
1-4 Installation Check	14
1-5 Precautions when servicing	14
1-6 Add liquid Precautions	14
2. Single-Screen Control Panel	15
2-1 Appearance control panel	15
Single screen distribution line diagram	16
2-2 Keys Operating Instructions	16
3 The single monitor thermostat mode general operating instructions	16
3-1 Startup off the cooling machine	16
3-2 Set the temperature control	16
3-3 Watch temperature	16
4. Single- screen controller function setting mode operating instructions	17
4-1 Enter Function setting mode	17
4-2 Modify the setting	17
4-3 THE END OF THE SET THE	17
The fault code information and troubleshooting	17
5. Dual screen Controller Description	18
5-1 Control Panel Appearance	18
5-2 Keys Operating instructions	18
6. Generally temperature control mode dual screen operating instructions	18
6-1 Startup off the cooling machine	18
6-2 Set the temperature control	18
6-3 Viewing room temperature	19
Dual screen the controller alarm signal description	19
7. Controllers wiring diagram	20
7-1 Wiring Precautions	20
7-2 The controller wiring diagram	20
8. Described of the parts reset	21
9. Care and Maintenance	22
Service certificate	23

1. General Precautions

Dear Customers :

Thank you for using the company's products , To ensure the accuracy and safety of use, please read the operating instructions. The company's products are many types of type and application specifications , Roughly divided into water cooling machine and oil cooling machine , Equipped with (oil / water tanks), no (oil / water tanks) , Or equipped with an (pump), no (pump), please pay special attention to the use of specifications.

1-1 Delivery check:

After the appearance of the machine to check whether the transport unloading collision damage , Specifications and requirements with quote meets to discuss when.

1-2 Precautions when transporting:

- When unloading machine Please use the appropriate forklift or crane.
- Note that when you using a rope and weight lifting machine tools to meet the load (weight indicated on the machine nameplate).
- Do not tilt or was placed horizontally during transportation.
- Please use rope or other means when transporting the machine fixed, to avoid collision damage when transporting mobile.

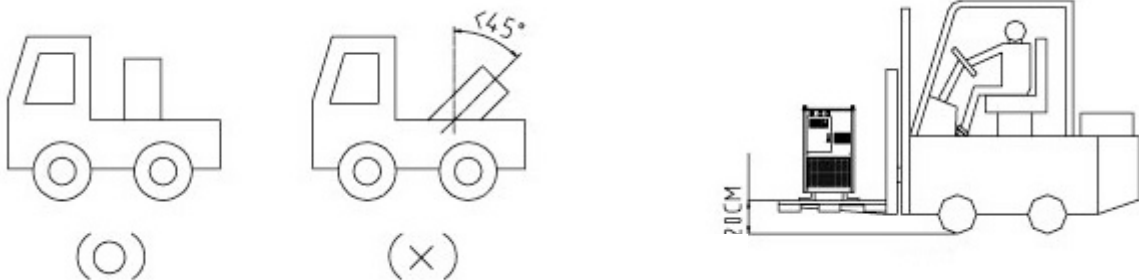

1-3 Precautions placed in.

- Place the machine in a horizontal position, avoid running the compressor or motor and other parts malfunction.
- Location to place the machine, the space around the machine must to stay at least 50cm above heat dissipation can not be placed in enclosed spaces at.
- Avoid placing in unventilated spaces for an ambient temperature of 5 ~ 40 °C .
- Avoid placing there is oil and gas, volatile liquid gas, away from dangerous places the source of the fire.
- Avoid placing in direct sunlight there is, or humidity, rain, lightning locations to prevent damage to electrical components shorted.
- After moving the machine required 30 minutes of

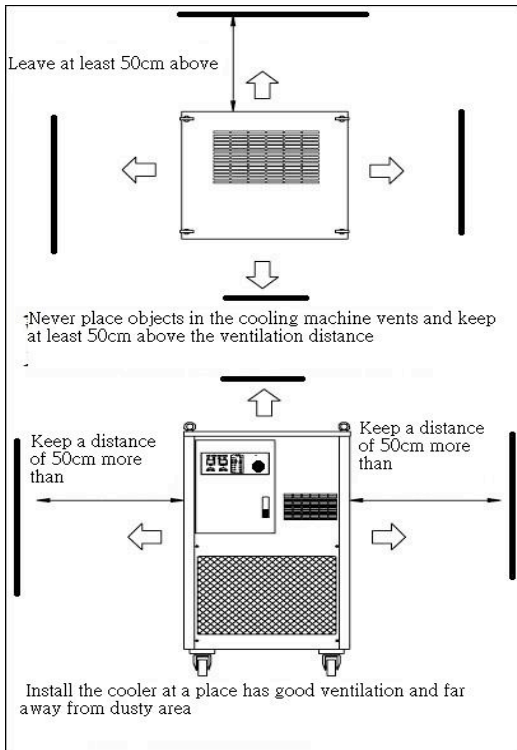

1-4 Installation Check:

- In the pipe to the inlet and outlet piping fittings are installed, and note whether the leaking piping fittings.
- Liquid level is added to the exact location (the HIGH level gauge marked).
- Before the start Various line ball valve is turned.
- Make sure the power supply and machine specifications, phase, voltage and frequency are met, please refer to the cooling machine nameplate current total consumption, to configure the correct diameter and power line protection switch.

Power terminal block wiring and fault point

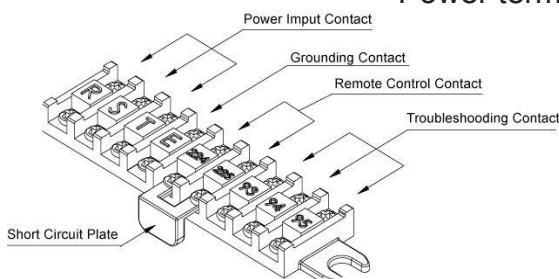

Wire Numbers	When the the normal operation		After the fault occurs	
93 . 95				
93 . 94				

1-5 PRECAUTIONS WHEN SERVICING:

- When servicing make sure the power is off.
- Dangerous non-professional maintenance staff Do not disassemble for sheet metal, to avoid (electric shock, fan blades wounding, burns) of.
- Keep cooling machine When the the total repair the power off, make sure cooling machine into the terminals No power before they can repairs.
- Cooling machine system repairs need of performed by a professional freezing repairs technicians.

1-6 Adding liquid Precautions

Liquids use restrictions :

Hydraulic pressure oil cooling machine for the Department of of mineral oils and lubricants ,
 Prohibited the use other coolant , (Recommended for No.2 to No. 68 oil designation oil).
 Water cooling machine is only suitable for water, or ethylene glycol, DI water (Prohibited the use
 highly volatile or flammable liquids and corrosive hazardous liquids).
 Oil viscosity is too high or too low for use , Pump will likely generated abnormal sounds or affect
 the cooling effect , In this case, replace the appropriate viscosity oil.
 Oil Viscosity Reference Table :

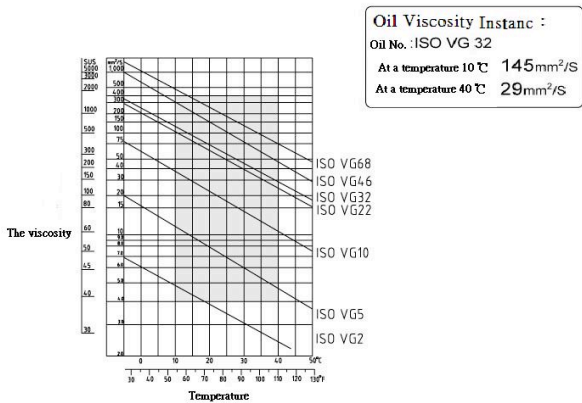

2. Single-Screen Control Panel

2-1 Control the panel appearance Temperature Windows

LED Description
POWER: Power indicator lights up after power
PUMP : Pumps indicator lights up pumps start
COOL : Compressor indicator light,
 When this light flashes to
ALALM: Alarm Indicator

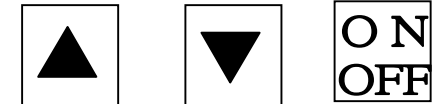
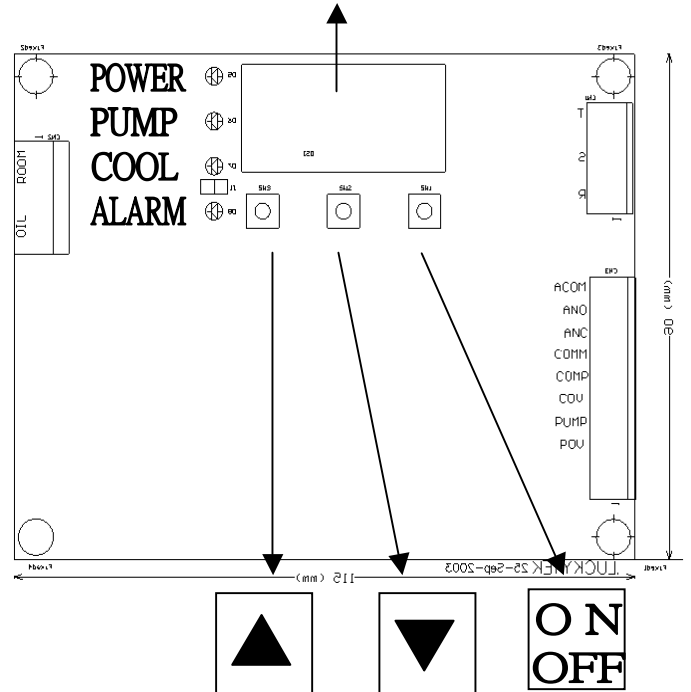

On the Down keys

Control the panel positive

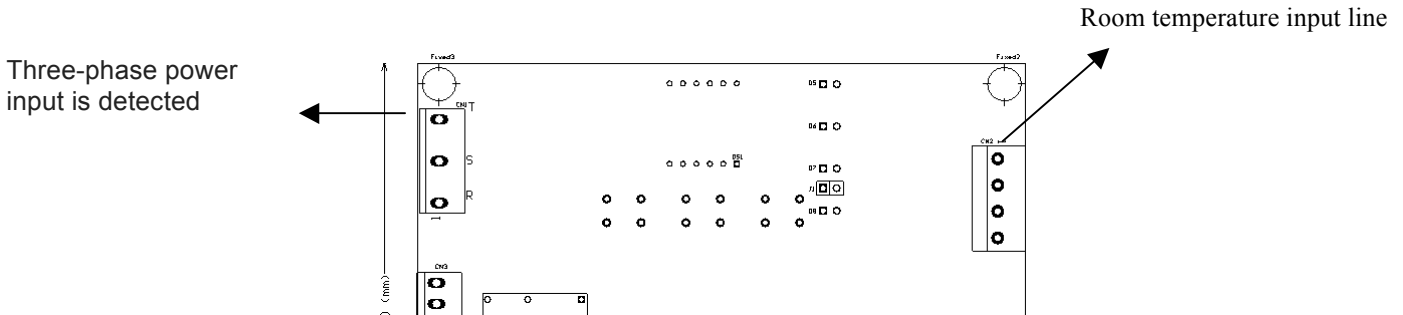

The output endpoint ←

→ Liquid temperature input line

Power Input ←
AC 8~12V

↓
Fuse AC 250V 2A/20mm F1

Control the panel backside

With single controller circuit diagram

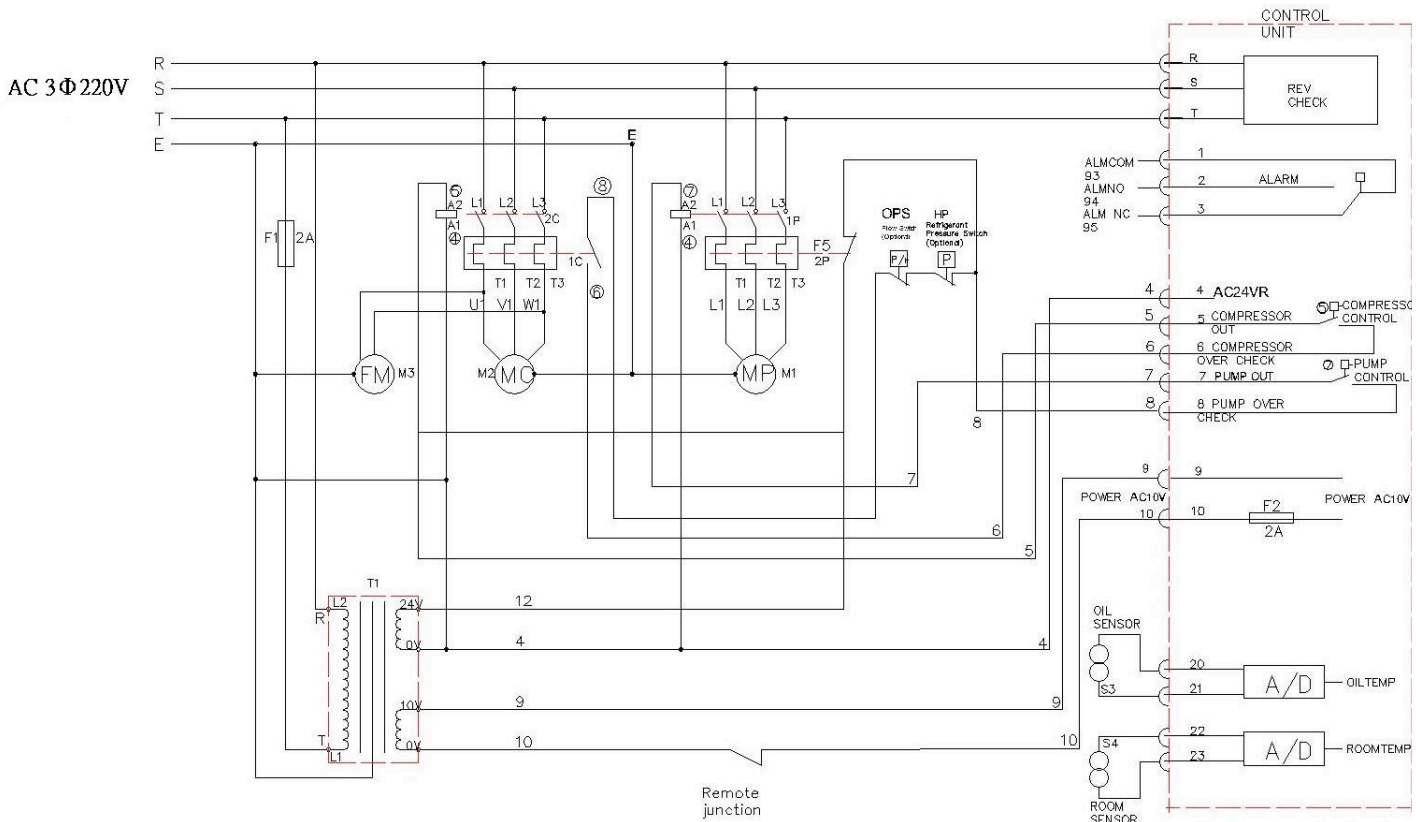

keys Operating Instructions:

General Mode button operation.

ON / **OFF** Close / activation controller.

Setting Mode: Select Options / press and hold 2 seconds to leave the set mode

▲: Increasing the setting / Open set.

: Decrease the value / display Room temperature.

3. Single-Screen Controllers General temperature controller mode operating instructions

3-1 Start off the cooling machine

 Click Launch, and then a close. If the function [F09] is set to ON, the power control from start to close.

3-2 Set temperature control

 To click into the temperature setting mode (temperature display flashes).

 Press Increasing the setting up, if you press the rapidly accumulating about 1 second later, until the maximum setpoint.

 Press Decrease the value, if you press quickly reduce after about 1 second until the minimum setting.

3-3 Viewing Room temperature

Press  Press and hold the, Window displays the Room temperature temperature (the last decimal point flashes) until you release keys.

4. Single- screen controller function setting mode operating instructions

4-1 Enter Function setting mode

Under normal condition, while holding down the   Will enter the function setting mode for about three seconds after.

After the [F01] to display 0.8 seconds and set the flash alternately. If set to [F10] will enter the function setting [F99] to enter the password, the display 0.8 seconds after setting the interaction with the blinking, enter the correct number into the [F01].

Password confirmation once before after the next power are not required to resend again to confirm.

4-2 Modify set value

 Press to increase set value, if you press about 1 second after accumulating rapidly, until the maximum set value

 Decrease the value, if you press quickly reduce after about 1 second until the minimum setting.

 Press Enter to confirm and save the settings into memory and switch to the next project setting options.

If no changes to set value will switch directly to the next project setting options.

After editing is no longer press the button, after about 3 seconds automatically stored into memory, options and settings interact flashes.

4-3 The end of the set

 Press and hold for about 2 seconds to return back to the general state of retreat display mode.

Single screen panel fault signal code

Alarm Code	Alarm Cause	Controller the action	Inspection and troubleshooting
[AL1]	Power reverse phase failed or phase (REV)	Pump running: OFF Compressor running: OFF Alarm lamp: ON	1. Use Multimeter to check the power supply there is not a normal, balanced 3-phase required within $\pm 10\%$. 2. For single-phase the machine, please set the F18 function key to OFF.
[AL2]	Motor overload (PUMP)	Pump running: OFF Compressor running: OFF Alarm lamp: ON	1. Check all import and export pipeline whether foreign body obstruction 2. Check the power supply is normal 3. Pumps overload settings are correct. 4. Press the reset motor overload protection.

[AL3]	Compressor overload(COMP) Liquid level insufficient flow pressure switch tripped (OPS) Refrigerant pressure switch tripped(HP)	Pump running:OFF Compressor running:OFF Alarm lamp:ON	1. Check the heat dissipation is not normal, heat dissipation fan is running。 2. Check the power supply is normal 3. Compressor overload protection settings are correct。 4. Check the water level in the water tank there is no lack of water to be added to more than 80% full。 5. There is no reverse Pumps。 6. Pumps suction inlet of whether foreign body obstruction。 7. Dirty filters or heat sink, poor heat dissipation。
[AL4]	Room temperature sensor fault line (RA)	Pump running:OFF Compressor running:OFF Alarm lamp:ON	Replace the Room temperature temperature sensor
[AL5]	Liquid temperature and temperature sensor line failure (RO)	Pump running:OFF Compressor running: OFF Alarm lamp :ON	Replace the liquid temperature temperature sensor
[AL6]	Overtemperature protection warning (OT)	Pump running : ON Compressor running: ON Alarm lamp : ON	1. Confirm overtemperature protection set parameter values。 2. Check the reason for can not be cooling。

5. Double Screen Control Panel

5-1 Control the panel appearance

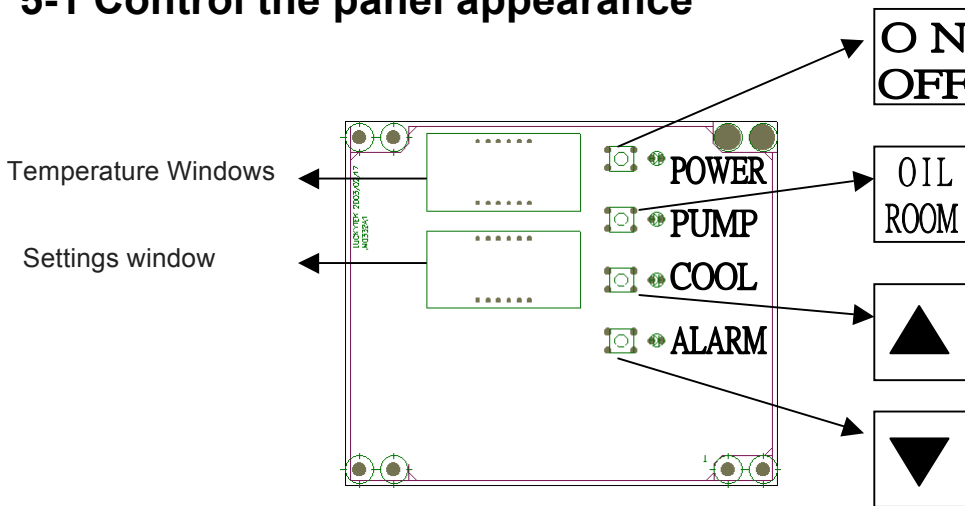

Three-phase power input

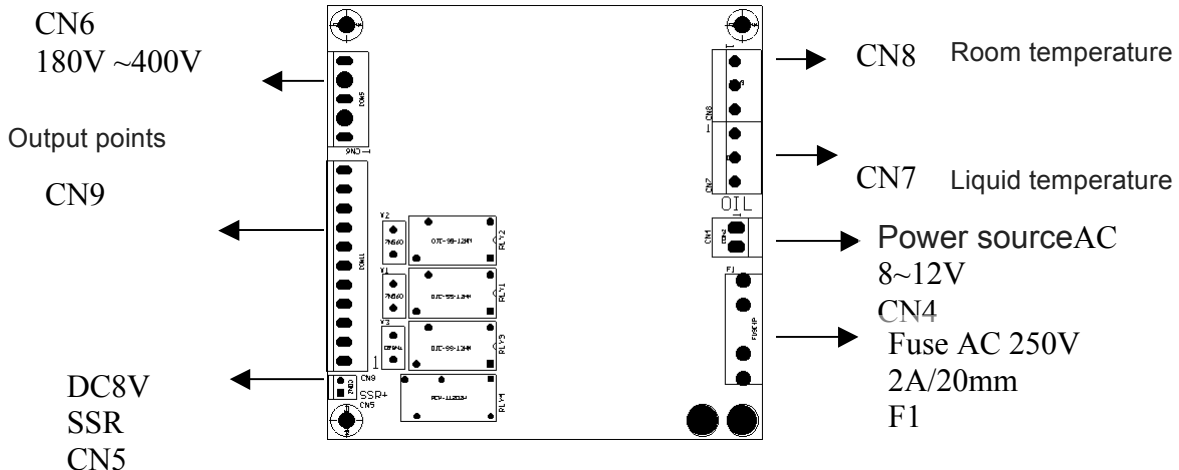

5-2: keys Operating Instructions:

 General Mode: Off / startup the controller Function setting mode: leave the setup mode

 Usually Mode: Displays room temperature for 5 seconds after the switch back to display the liquid temperature. Function Setting Mode: select the setting item.

 : Setting data to the increase.

 : Setting data to the lower.

6. GENERALLY TEMPERATURE CONTROL MODE DUAL SCREEN OPERATING INSTRUCTIONS

6-1 Startup off the cooling machine

 Press to start, and then click Close.

6-2 Set temperature control

 Press to increase set value, if you press about one second after accumulating rapidly, until the maximum set value.

 Press to decrease the setting, if you press quickly reduce after about one second until the minimum setting.

After editing is no longer press the button, it will automatically stored in memory for about two seconds after.

6-3 Viewing room temperature

 Click the, window displays the room temperature temperature, and cut back to five seconds after flashing display liquid (water) temperature.

Dual screen the controller alarm signal description

Alarm Code	Alarm Cause	Controller the action	Inspection and troubleshooting
[AL1]	Power reverse phase failed or phase (REV)	Pump running:OFF Compressor running:OFF Alarm lamp:ON	1. Use Multimeter to check the power supply there is not a normal, balanced 3-phase required within $\pm 10\%$. 2. For single-phase the machine, please set the F18 function key to OFF.
[AL2]	Insufficient water (OPS)	Pump running : ON Compressor running: OFF Alarm lamp : ON	1. Check all import and export pipeline whether foreign body obstruction 2. Check the power supply is normal 3. Pumps overload settings are correct.
[AL3]	Pump overload. (PUMP)	Pump running : OFF Compressor running: OFF Alarm lamp : ON	1. Check all import and export pipeline whether foreign body obstruction 2. Check the power supply is normal 3. Press the reset motor overload protection.
[AL4]	Compressor overload (COMP)	Pump running : ON Compressor running: OFF Alarm lamp : ON	1. dissipation is not normal, heat dissipation fan is running. 2. Check the power supply is normal 3. Compressor overload protection settings are correct. 4. Dirty filters or heat sink, poor heat dissipation

[AL5]	Freon pressure switch tripped (HP)	Pump running : ON Compressor running: OFF Alarm lamp : ON	Check whether the normal heat dissipation, dirty filter or radiators, poor heat dissipation. Exclude the heat problem, or heat dissipation fan failure.
[AL6]	Room temperature sensor fault line (RA)	Pump running : ON Compressor running: OFF Alarm lamp : ON	Replace the Room temperature temperature sensor
[AL7]	Liquid temperature and temperature sensor line failure (RO)	Pump running: ON Compressor running:OFF Alarm lamp:ON	Replace the liquid temperature temperature sensor
[AL8]	Overtemperature protection warning (OT)	Pump running : ON Compressor running: ON Alarm lamp : ON	1.Confirm overtemperature protection set parameter values。 2.Check the reason for can not be cooling。
[AL9]	Hypothermia protection warning, (LT)	Pump running : ON Compressor running:OFF Alarm lamp :ON	1. Check the low temperature protection set value。 2. Calibration temperature sensor。
Power light is on, but no display monitor	No the boot after power	Pump running : OFF Compressor running: OFF Alarm lamp : ON	Click the on the panel on / off button

7.CONTROLLERS WIRING DIAGRAM

7-1 Wiring Precautions

- When installing boards or other peripherals are connected, all power must be turned off, or there may be an electric shock or equipment damage
- In line with all the installation work, check to see if the power supply and each pin has a short circuit, be sure there is no electricity after test.
- The main power line to provide the board of twisted pair to reduce interference signals.
- Temperature line in conjunction with power lines close to avoid interfering signals caused by inaccurate temperature display.
- For environments with fumes, dust, electrical conductivity, high temperature, high humidity, corrosive gas, flammable gas, with rain or condensation, and high shock vibration environments Do not use spaces. If you want to use, please do protection measures.

7-2 Electrical wiring diagram dual screen the controller

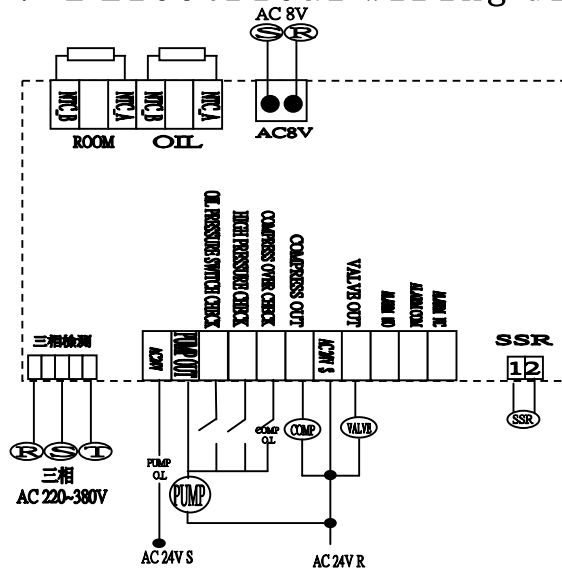

MC Compressor	MP Pump motor	PE Ground wire
51C Compressor motor solenoid switch	51P Pump motor solenoid switch	ST-RY startup Relays
HP Refrigerant Pressure Switch	OPS Liquid pressure switch	RA room temperature sensing line
51C O.L Compressor overload switch	51P O.L Pump motor overload switch	RO Liquid temperature sensing line
CS Start capacitor	RL Relays	TF Transformer
49C Compressor Automatic overheating switch	FS Fuse	

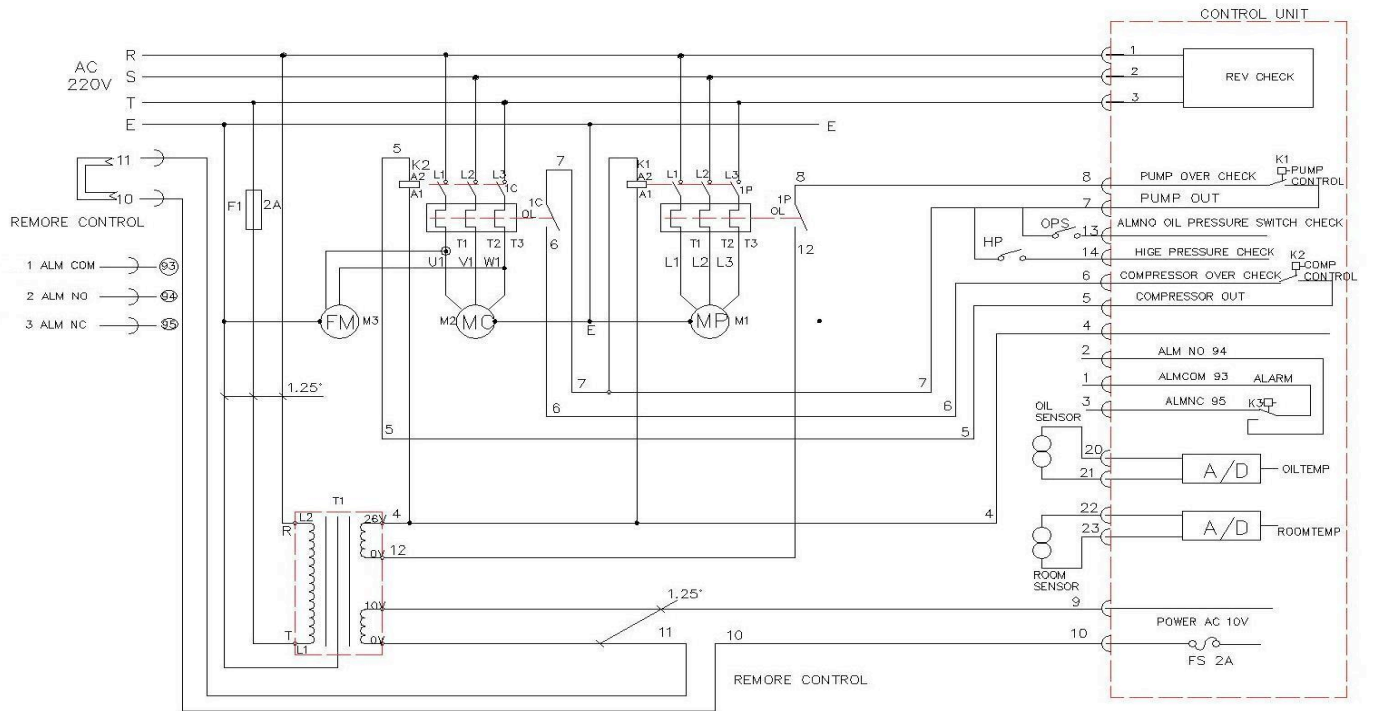

8. Of the parts is reset instructions

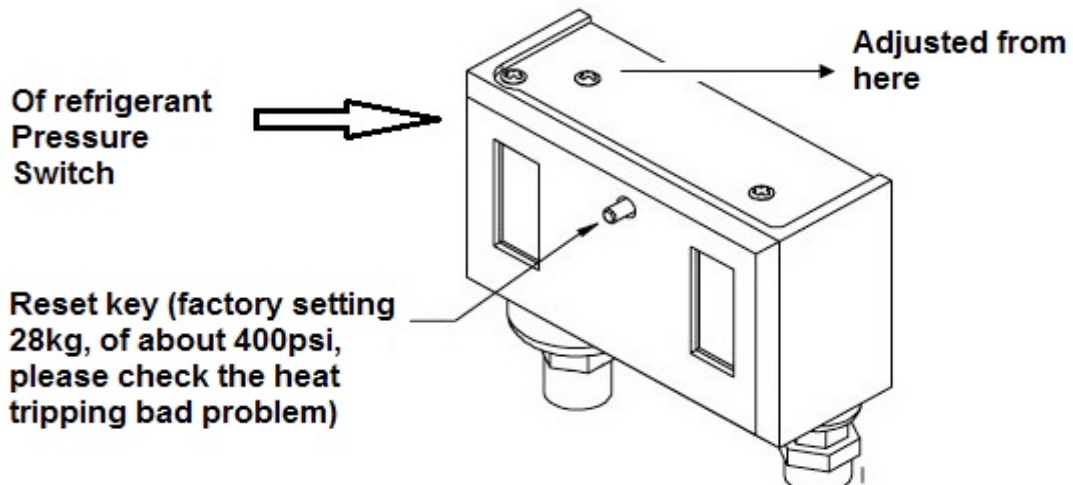
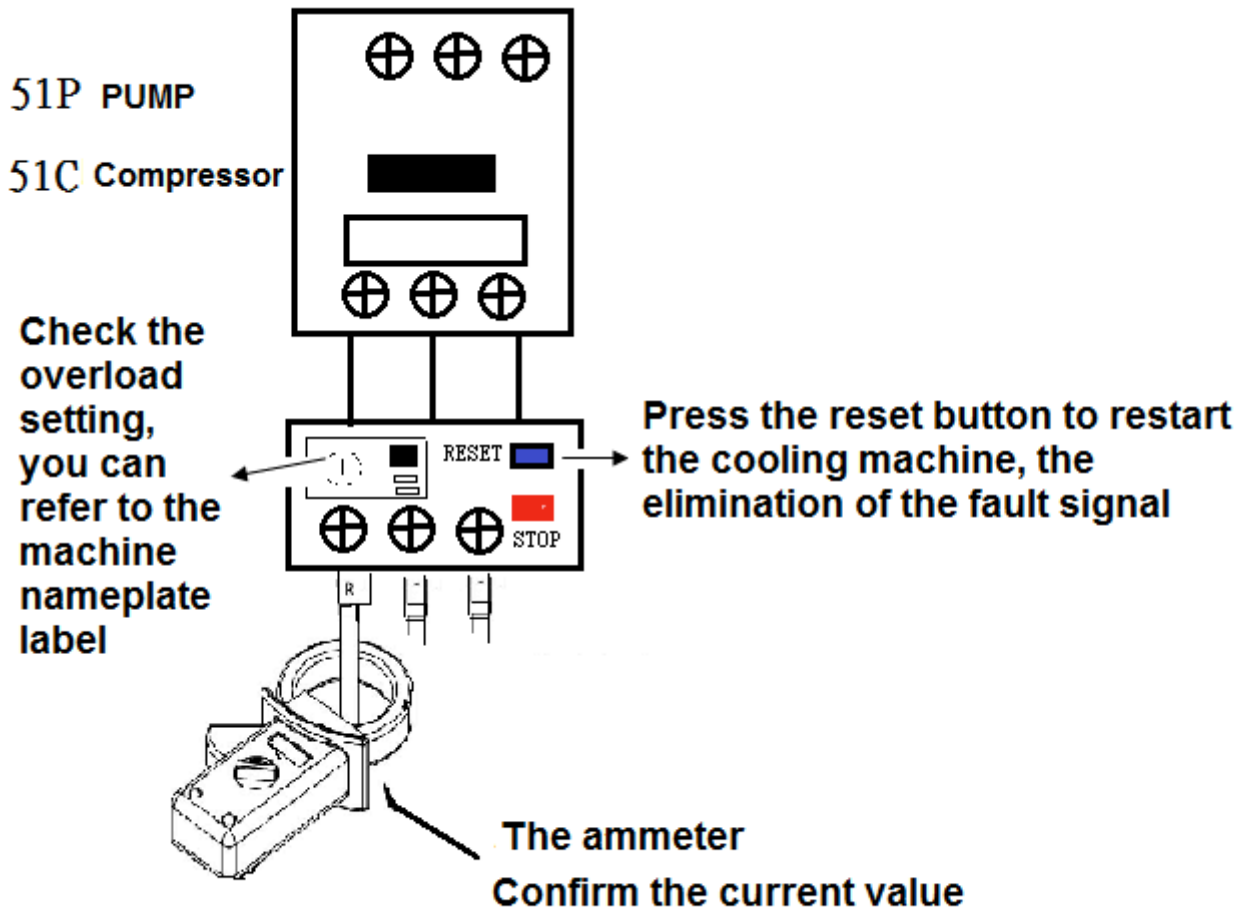

9. Care and Maintenance

- **When maintenance, be sure to cool off the power switch, avoid touching the heat or touching the fan, causing injury.**
- **Airframe maintenance, use neutral detergent or soap to clean surface dirt, do not use an acidic solvent paint surface to prevent corrosion.**
- **Do not put water spray cleaning to electronic control part, in order to avoid electrical appliances damage.**
- **Regular filter cleaning and maintenance, regular weekly use of airbrush cleaning of dust, rinse with water or cleaning agents.**
- **Regular use of compressed air to remove dust from the condenser, air spray gun shall be perpendicular to the direction of the upper and lower fin blowing.**
- **If the cooling machine import or export position has installed a filter, replace or clean the filter regularly cotton.**

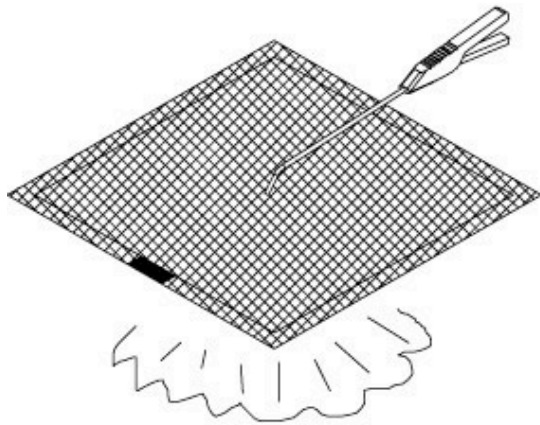

Use compressed air to filter cleaning

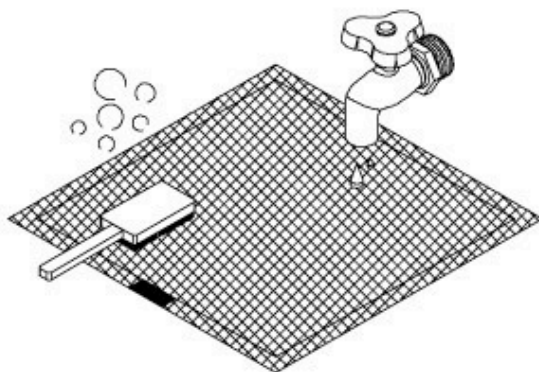

Use a mild detergent to clean the filter



Periodically replace the filter